

Using a Mach-Zehnder Interferometer to Illustrate Feynman's Sum Over Histories Approach to Quantum Mechanics

Frank Rioux
Department of Chemistry
CSB|SJU

Thirty-one years ago Dick Feynman told me about his 'sum over histories' version of quantum mechanics. "The electron does anything it likes," he said. "It just goes in any direction, at any speed, forward and backward in time, however it likes, and then you add up the amplitudes and it gives you the wave function." I said to him "You're crazy." But he isn't. **Freeman Dyson, 1980.**

In Volume 3 of the celebrated *Feynman Lectures on Physics*, Feynman uses the double-slit experiment as the paradigm for his 'sum over histories' approach to quantum mechanics. He said that any question in quantum mechanics could be answered by responding, "You remember the experiment with the two holes? It's the same thing." And, of course, he's right.

A 'sum over histories' is a superposition of possible experimental outcomes which in quantum mechanics carry phase and therefore interfere constructively and destructively with one another. The square of the magnitude of the superposition of histories yields the probabilities that the various experimental possibilities will be observed.

Obviously it takes a minimum of two 'histories' to demonstrate the interference inherent in the quantum mechanical superposition. And, that's why Feynman chose the double-slit experiment as the paradigm for quantum mechanical behavior. The two slits provide two paths, or 'histories' to any destination on the detection screen. In this tutorial, a close cousin of the double-slit experiment, single particle interference in a Mach-Zehnder interferometer, will be used to illustrate Feynman's 'sum over histories' approach to quantum mechanics.

A Beam Splitter Creates a Quantum Mechanical Superposition

Single photons emitted by a source (S) illuminate a 50-50 beam splitter (BS). Mirrors (M) direct the photons to detectors D_1 and D_2 . The probability amplitudes for transmission and reflection are given below. By convention a 90 degree phase shift (i) is assigned to reflection.

Probability amplitude for photon transmission at a 50-50 beamsplitter: $\langle T|S\rangle = \frac{1}{\sqrt{2}}$

Probability amplitude for photon reflection at a 50-50 beamsplitter: $\langle R|S\rangle = \frac{i}{\sqrt{2}}$

After the beam splitter the photon is in a superposition of being transmitted and reflected.

$$S = \frac{1}{\sqrt{2}} \cdot (T + iR)$$

As shown in the diagram below, mirrors direct the transmitted photon to D_1 and the reflected photon to D_2 . This can be expressed quantum mechanically as shown below.

$$T = D_2 \quad R = D_1$$

Expressing the source photon in the basis of the detectors we have,

$$S = \frac{1}{\sqrt{2}} \cdot (T + iR) \quad \left| \begin{array}{l} \text{substitute, } T = D_2 \\ \text{substitute, } R = D_1 \end{array} \right. \rightarrow S = \frac{1}{2} \cdot 2^{\frac{1}{2}} \cdot (D_2 + i \cdot D_1)$$

$$\text{Probability}_{D_1} = \left(\left| \frac{i \cdot \sqrt{2}}{2} \right| \right)^2 \rightarrow \text{Probability}_{D_1} = \frac{1}{2} \quad \text{Probability}_{D_2} = \left(\left| \frac{\sqrt{2}}{2} \right| \right)^2 \rightarrow \text{Probability}_{D_2} = \frac{1}{2}$$

The square of the magnitude of the coefficients of D_1 and D_2 give the probabilities that the photon will be detected at D_1 and D_2 . As shown below, each detector register photons 50% of the time in agreement with this analysis.

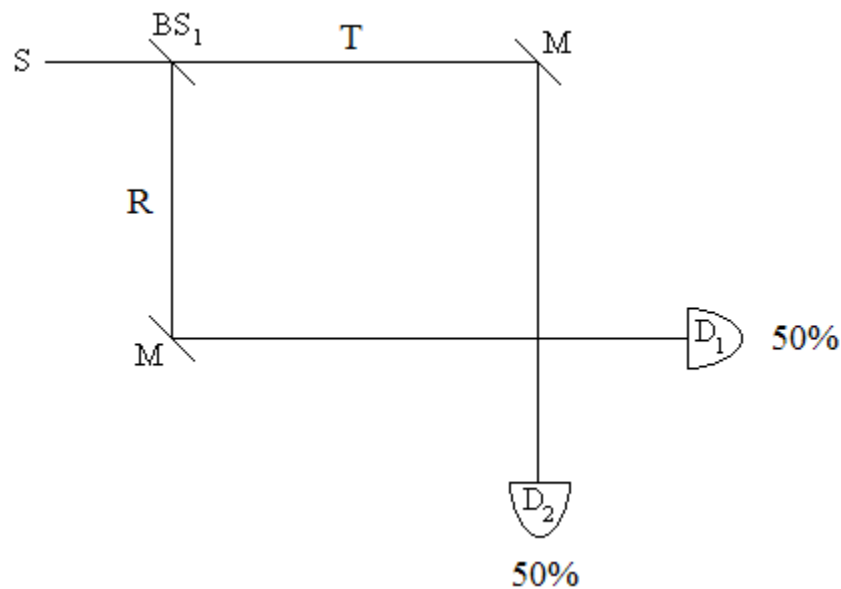

A Second Beam Splitter Provides Two Paths (Histories) to the Detectors

If a second beamsplitter is inserted before the detectors as shown below, the photons always arrive at D_1 . The purpose of this tutorial is to analyze this experiment from several perspectives. The crux of the matter is that in the first experiment there was only one path (history) to each detector. The construction of a Mach-Zehnder (MZ) interferometer by the insertion of a second beamsplitter creates a second path (another history) to each detector. The probability amplitudes for these paths (histories) interfere constructively for D_1 and destructively for D_2 .

The histories of a photon arriving at D_1 is the sum of being transmitted at BS_1 and reflected at BS_2 and reflected at BS_1 and transmitted at BS_2 ($TR + RT$). The individual histories are in phase at D_1 , having been shifted by 90 degrees from the source.

The 'history' of a photon arriving at D_2 is the sum of being transmitted at BS_1 and transmitted at BS_2 and reflected at BS_1 and reflected at BS_2 (TT + RR). These histories are 180 degrees out of phase at D_2 .

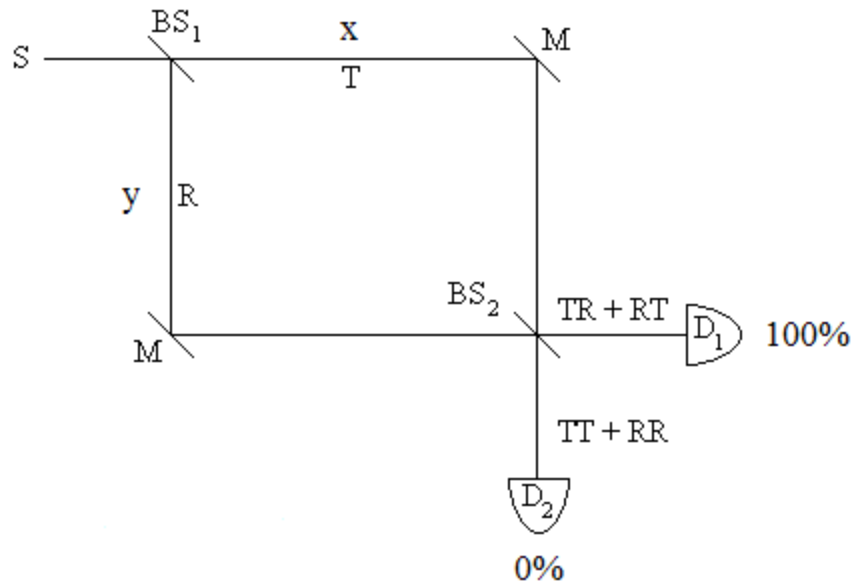

The mathematics of this approach is described below. After the first beam splitter the photon is in superposition of being transmitted and reflected.

$$S = \frac{1}{\sqrt{2}} \cdot (T + iR)$$

After the second beam splitter we have the following superpositions for the transmitted and reflected branches, which are then substituted into the first equation to get the probability amplitudes for arriving at the D_1 and D_2 .

$$T = \frac{1}{\sqrt{2}} \cdot (i \cdot D_1 + D_2) \quad R = \frac{1}{\sqrt{2}} \cdot (D_1 + i \cdot D_2)$$

$$S = \frac{1}{\sqrt{2}} \cdot (T + iR) \left\{ \begin{array}{l} \text{substitute, } T = \frac{1}{\sqrt{2}} \cdot (i \cdot D_1 + D_2) \\ \text{substitute, } R = \frac{1}{\sqrt{2}} \cdot (D_1 + i \cdot D_2) \rightarrow S = i \cdot D_1 \\ \text{simplify} \end{array} \right.$$

$$\text{Probability}_{D_1} = (|i|)^2 \rightarrow \text{Probability}_{D_1} = 1$$